

Designing a Buck Converter

Designing a buck converter can be an overwhelming task. We want a box that works - taking in one DC voltage and giving us another. Of course, this box can take a number of forms: step-down to generate a lower voltage, step-up to generate a higher voltage and lots of specialties like step-up/step-down, flyback and sepic converters. If you are designing a system to run on AC power, your first AC-to-DC block will probably create the highest DC voltage level needed by your system. Therefore, the most widely used converters are step-down converters.

For this discussion, we will limit ourselves to step-down converters. Furthermore, we will choose a switching regulator because it has the highest efficiency of converter types. This high efficiency means less energy is lost in the conversion so thermal management is easier as well. Figure 1 shows the basics of a type of step-down switching regulator, a synchronous buck converter. The term synchronous buck indicates that a MOSFET is used as the lower switch. Comparatively, a standard buck regulator has a Schottky diode as a lower switch. The main benefit of a synchronous buck regulator versus a standard buck regulator is better efficiency due to a lower voltage drop of the MOSFET versus a diode.

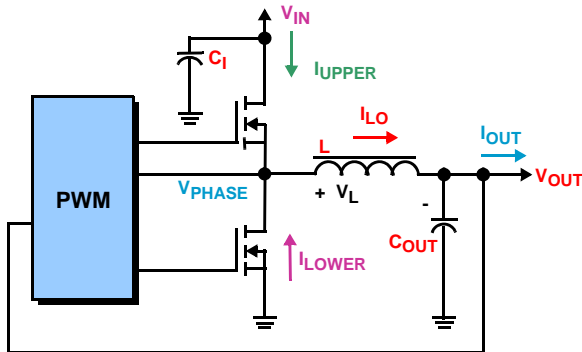

FIGURE 1. BASICS OF A SYNCHRONOUS BUCK CONVERTER

The timing information for the lower and upper MOSFETs is provided by a pulse-width modulation (PWM) controller. The input to the controller is a voltage fed back from the output. This loop allows the buck converter to regulate its output in response to load changes. The output of the PWM block is a digital signal toggling up and down at the switching frequency. This signal drives the MOSFET pair. The duty cycle of this signal determines what percentage of the time the input is directly connected to the output. Therefore, the output voltage is the product of input voltage and this duty cycle.

Choosing the IC

The control loop allows the buck converter to maintain a steady output voltage. That loop can be implemented in a number of ways. The simplest converters use either voltage or current feedback. These converters, like the Intersil ISL6341, are rugged, straightforward, and cost-effective. As buck converters began to be used in a variety of applications, a weakness was found. Consider the power circuitry for a graphics card. As the video content changes, so does the load

on the buck converter. The system can handle a wide range of changes, but it was noticed that the efficiency degraded for light load conditions. If efficiency is a concern, then a better buck converter solution is needed. One such improvement is called hysteretic control. One example is the Intersil ISL62871. The efficiency vs load is presented in Figure 2.

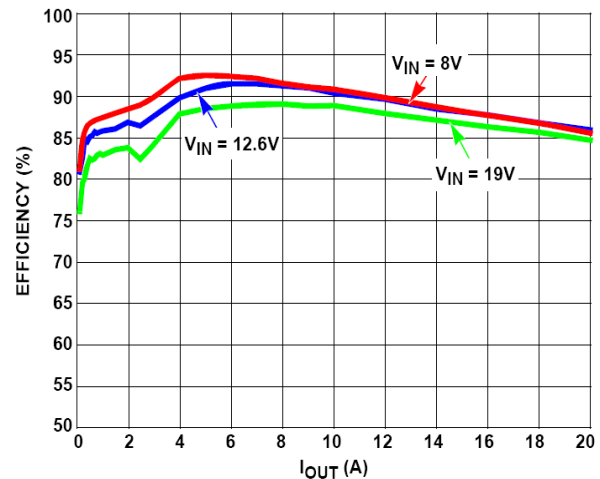

FIGURE 2. EFFICIENCY vs LOAD FOR THE ISL62871 WITH V_{OUT} = 1.1V

Realize that these converters are designed for worst case conditions (don't want anything blowing up), so light load is not a permanent situation. These DC/DC converters are better at coping with changes in load variations without drastically affecting the system efficiency.

Choosing the Switching Frequency

Both of the devices selected as examples have fixed switching frequencies. In fact, they have the same switching frequency: 300kHz. Although it is not a concern with these two parts, it is worth discussing the switching frequency. The chief trade-off with switching frequency is efficiency. In the simplest terms, the MOSFETs have a certain turn-on and turn-off time. As the frequency increases, this transitional time becomes a larger and larger percentage of the total time. Thus, the efficiency is reduced. So if efficiency is your most important design goal, consider lowering the switching frequency. If the efficiency of your system is adequate, then allow a higher switching frequency. The higher frequency will allow you to use smaller external passive components, namely the output inductor and capacitors.

External Components

For a challenge (and probably not for production), you might choose to build your own discrete solution. This would take approximately 40 components. Most of us would prefer a simpler solution requiring less effort. In the previous section we have offered two suggestions for the IC. In the voltage-mode

Application Note 1663

buck converter design, the external components and their parasitics play a large role in the performance of the system. These will be detailed as we address each component.

With this particular buck converter, we must select five additional components, the input capacitance, the output capacitance, the output inductor, the upper and lower MOSFETs. The output inductor is selected to meet the output ripple requirements and to minimize the PWM's response time to a transient load. The lower bound of possible inductor values is set by the ripple requirement. Before running out to find the smallest (and possibly cheapest) inductor that will work for you, remember that they are not ideal. Real inductors have a saturation level. That saturation level must be higher than the peak current in your system for you to have a successful design. Experienced designers also know that the inductance isn't constant versus current. In fact, the value of inductance drops as you pull more current through the component. Check the inductor datasheet to ensure that your chosen value is sufficient with the peak current in your system. So far, it seems that erring on the larger side might be best for your inductance choice. Be careful, though. Larger values of inductance will reduce your output ripple, but they will also limit the slew rate. Eventually, a large inductance will limit your response time to a load transient. So, in selecting your inductor there is a clear trade-off between a quieter output due to lower peak-to-peak ripple or needing the system to respond quickly to a transient event.

The input capacitance is responsible for sourcing the AC component of the input current flowing into the upper MOSFET. Therefore, their RMS current capacity must be sufficient to handle the AC component of the current drawn by that upper MOSFET. It is common to use a mix of input bypass capacitors at this point. For quality and low temperature coefficient, ceramic capacitors are chosen to decouple the high frequency components. Bulk capacitors supply the lower frequency RMS current, which is tied to the duty cycle. (More RMS current when the system is operating further from 50% duty cycle.) The bulk capacitance can be several multi-layer ceramic capacitors. In lower cost applications, however, several electrolytic capacitors are typically used in parallel. In surface mount designs, solid tantalum capacitors may be chosen for the bulk capacitance, but be careful to note the capacitor's surge current rating. (Surge currents are common at start-up.)

When choosing any capacitor in the buck converter system, look for small equivalent series inductance (ESL), small equivalent series resistance (ESR) and finally, the total capacitance required. As always, optimize your choice within your budget.

There is one final note in regard to capacitor voltage ratings. To minimize hard-to-find failures, choose capacitors with ratings 1.2 to 1.3 times greater than the input voltage (the voltage across them).

The output capacitor must filter the output and supply current to the load during a transient event. Interestingly, the equivalent series resistance (ESR) and voltage rating have more effect on

the choice of capacitor than the actual capacitance value. Notice that the peak-to-peak current ripple from our inductor is transformed into peak-to-peak voltage ripple by the ESR of the output capacitor. Since your system probably has a limit on output voltage ripple, you must choose a capacitance (or set of parallel capacitors) that will minimize the ESR. Of course, you need to choose capacitors that have sufficient voltage rating. With this combination of requirements, approach the capacitor tables from your vendors to find a suitable solution. One final caution, pay extra attention to the ESR data; it might not be given in the table at the same frequency as your switching frequency. Check the component datasheet for adjusted values of ESR.

The MOSFETs are typically chosen for $r_{DS(ON)}$, total gate charge and thermal management requirements. Review several manufacturers' datasheets. Choose something like the Infineon BSC050N03LS with 35nC of gate charge and $r_{DS(ON)}$ of 5m Ω for the upper MOSFET. Complement that with the $r_{DS(ON)}$ of 1.6m Ω for the lower MOSFET (BSC016).

Closing the Loop

As discussed earlier, the output is fed back to the input. This connection creates a compensation loop. There are various types of compensations, such as Type I, Type II, and Type III. Type I compensation is a single-pole solution, Type II is a two-pole solution with one zero and Type III is a three-pole solution with two zeroes. Each type increases in component count from the previous one, yet also allows for greater flexibility in design. For performance, set the bandwidth of this loop to be approximately a quarter of the switching frequency. The higher the crossover frequency of the loop, with regard to the actual switching frequency, yields a faster loop response. In addition, make sure the phase margin is greater than 30 degrees and less than 180 degrees, a typical stability criterion.

If you chose a hysteretic buck converter instead of a voltage-mode converter, the design process is similar. Luckily, the high quality hysteretic-mode control overshadows the parasitics of the external components. Otherwise, the process is similar.

The process of designing a buck converter is traced in this article. After choosing a controller IC, we select the accompanying external components. There are different parameters that are important for each selection.

Once the MOSFETs, output inductor, input and output capacitors are chosen, finish with compensation.

Most of us who understand how much understanding and work goes into designing a good buck converter are relieved to find out that more integrated versions are available. Some designs have integrated MOSFETs. Some designs integrate the compensation. A select few have integrated the output inductor as well.

One such offering is Intersil's ISL8201M. All that is needed is a resistor to set the output voltage, an input capacitor and an output capacitor. That is good news for busy system designers and folks who don't want to read more articles like this.

Intersil Corporation reserves the right to make changes in circuit design, software and/or specifications at any time without notice. Accordingly, the reader is cautioned to verify that the Application Note or Technical Brief is current before proceeding.

For information regarding Intersil Corporation and its products, see www.intersil.com